

PICKET RAIL ELEVATION

**FOR DESIGN INTENT ONLY,
NOT FOR INSTALLATION!**

NOTES:

1. MATL: ALUMINUM EXTRUSIONS 6063-T5
POST EXTRUSIONS 6061-T6
2. FINISH: ESP BAKED POWDER COAT
3. COLOR: CUSTOMER TO SPECIFY
4. SHOP WELDED FABRICATION AND ASSEMBLY (U.N.)
5. FIELD VERIFICATION AND INSTALLATION BY WHITE ALUMINUM.
6. IRON-FREE, NON-SHRINK GROUT
7,000 PSI MIN.
7. ALL HARDWARE SHALL BE RUST RESISTANT AND COMPATIBLE.
8. MATERIAL SHALL BE AS REQUIRED BY DESIGN AND CALCULATIONS.
9. MATERIAL ORDER SHALL NOT COMMENCE UNTIL DRAWING APPROVAL BY CUSTOMER.
10. RAIL FABRICATION SHALL COMMENCE AFTER FIELD DIMENSIONS BY WHITE ALUMINUM.

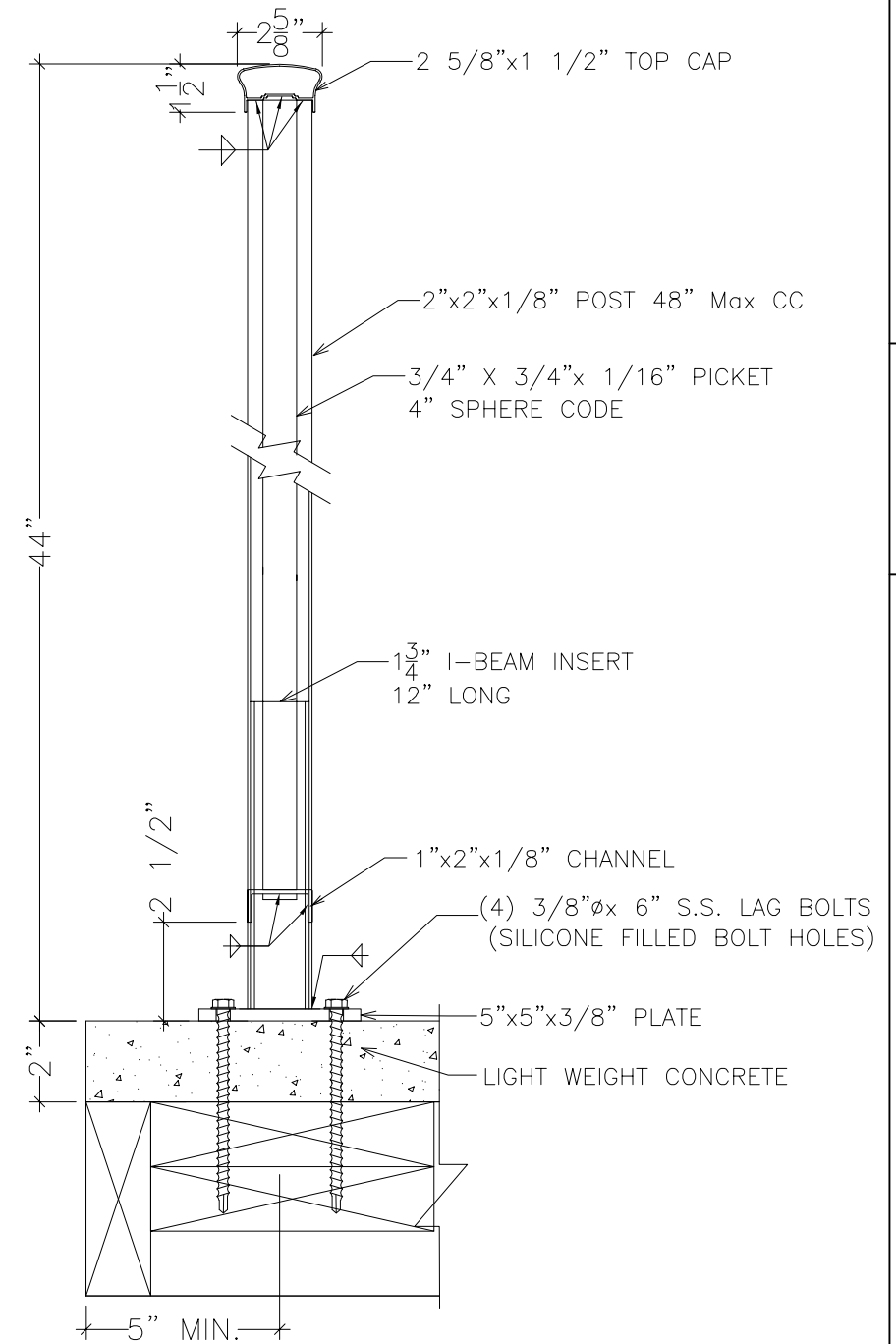

**SECTION A-A
(N.T.S.)**

SCALE: AS NOTED		PROJECT:	DRAWN BY: R. F.
DATE: 03/14/19		DRAWING DESCRIPTION:	CHECKED BY: R. W.
CUSTOMER:		2-LINE PICKET BASE PLATE	
DRAWING NUMBER:		SAMPLE	REV.
FAX: 561-219-3246		WHITE ALUMINUM FABRICATION, INC.	
TEL: 561-219-3245		3497 S.E. LIDNELL TERR. STUART, FL. 34997	